



**DATA SHEET  
ELA-TR4-4G  
FOCUS SHIFTER**

---

**NEWSON NV**

## Table of Contents

<b>1</b>	<b>ELA-TR4 .....</b>	<b>3</b>
<b>2</b>	<b>TYPICAL CHARACTERISTICS ELA-TR4-4G .....</b>	<b>4</b>
2.1	SPECIFICATIONS .....	4
<b>3</b>	<b>TYPICAL LENS SETUP .....</b>	<b>5</b>
<b>4</b>	<b>LENS MOUNTING.....</b>	<b>6</b>
<b>5</b>	<b>COMMUNICATION WITH ELA-TR4 FOCUS SHIFTER.....</b>	<b>7</b>
5.1	MODULATION ELECTRONICS .....	7
5.2	INSTRUCTION SET .....	8
5.2.1	20 BIT ABSOLUTE SET POINT CONTROL .....	8
5.2.2	16 BIT ABSOLUTE SET POINT CONTROL .....	9
5.3	POWER UP SEQUENCE .....	11
<b>6</b>	<b>DIMENSIONS.....</b>	<b>12</b>
6.1	ELA-TR4 WITH STANDARD HOUSING .....	12
6.2	ELA-TR4 ACTUATOR .....	13

## 1 ELA-TR4

An ELA-TR4 laser focus shifter is a device used to dynamically adjust the focal point of a laser beam. This adjustment allows for precise control over the position and focus of the laser, which is essential in various applications, such as:

- **Laser Microscopy:** Enhancing the resolution and depth of field by adjusting the focus on different layers of the specimen.
- **Materials Processing:** Fine-tuning the focus for cutting, engraving, or welding different materials to achieve the desired precision and quality.

The focus shifter can achieve these adjustments through moving a fixed lens 4 mm mechanically.

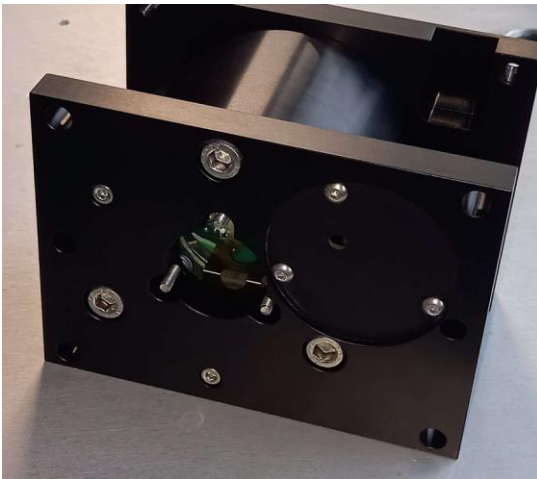

## 2 TYPICAL CHARACTERISTICS ELA-TR4-4G

### 2.1 SPECIFICATIONS

#### *General*

Actuator principle	moving coil	
Coil inductance		μH
Coil resistance	1.5	Ohm
Regulator	digital 20 bit	
Amplifier	class D	
Position sensor	AIMS (patented)	
Electrical connection	SMA connector	
Dimension	109 x 70 x 80	mm
Weight	0.8	kg
Cooling	No active cooling required	
Bearing	Spring bearing	

#### *Moving lens*

Supported metric diameters	15, 25	mm
Supported inch diameters	0.5, 1	inch
Edge thickness	2 to 5	mm

#### *Fixed lens*

Supported metric diameter	25	mm
Supported inch diameter	1	inch
Edge thickness	2 to 5	mm

#### *Positioning*

Clear aperture	20	mm
Velocity (max.)	400	mm/sec
Travel range (mechanical)	4	mm
Repeatability	65	nm
Track delay	1	ms

#### *Temperature*

Operating ambient temperature	-10 to +50	°C
Storage temperature	-10 to +60	°C

### 3 TYPICAL LENS SETUP

A typical lens setup of a focus shifter is that of a Galilean beam expander, in which an objective lens with a negative focal length and an image lens with a positive focal length are separated by the sum of their focal lengths.

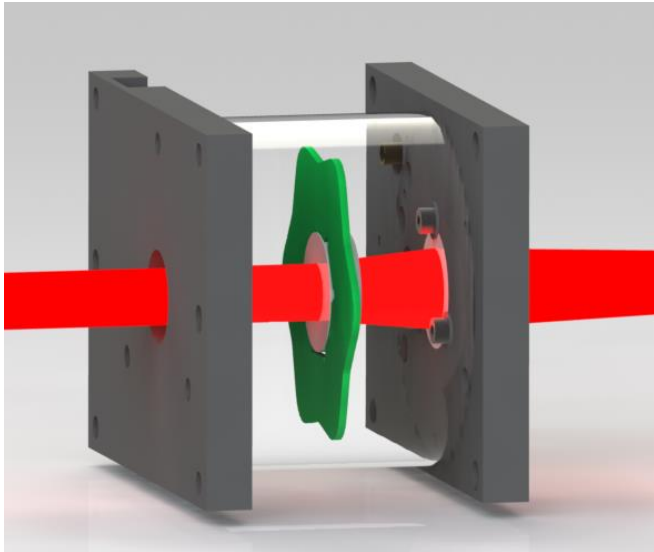

By mechanically shifting the negative focal length lens the output beam divergence will vary.

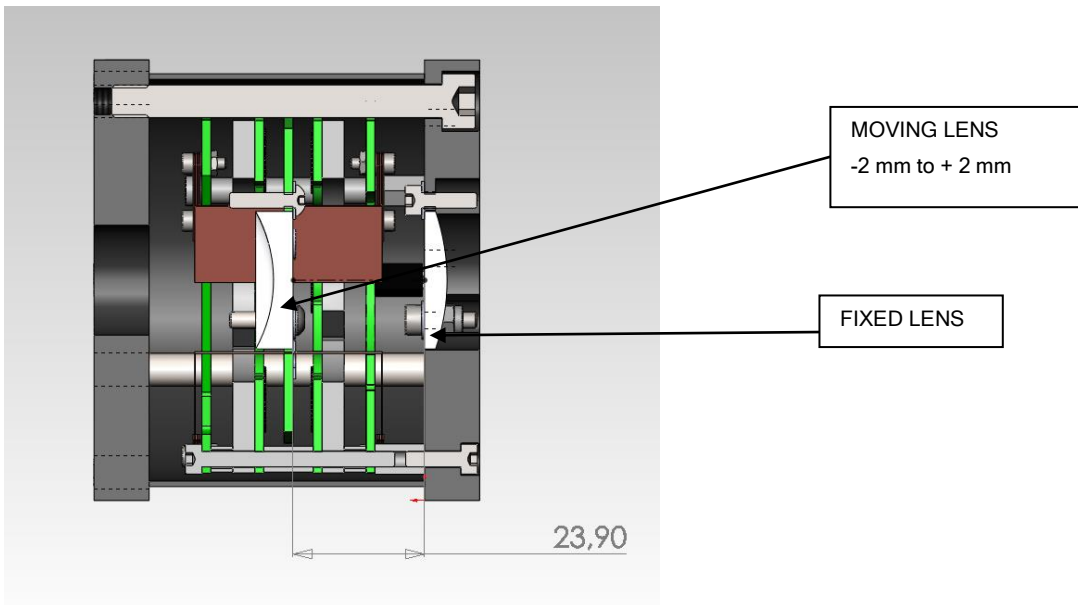

Inside the focus shifter the lens reference planes are 23.9 mm apart from each other when the focus shifter is regulating in 0 position. Depending on the desired lens combination lenses can be mounted with spacers to get a desired distance between moving and fixed lens.

## 4 LENS MOUNTING

Lenses inside a focus shifter are hold in place through lens fixtures, washers, screws and nuts. Depending on lens diameter and lens edge thickness different lens mounting parts are needed.

Lens exchange can be done by the customer itself. Special studs are available to fix the feather bearing during exchange of the lenses. The bearing is the most critical part inside the focus shifter. Putting radial force into the bearing will cause severe damage to the actuator.

Below an impression of a lens mounting.

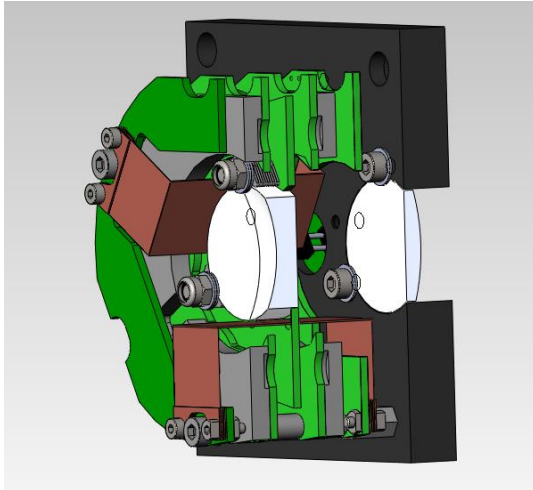

For the moving lens the PCB contains threaded holes for M3 screws. M3x10mm screws are pre-mounted. The lens itself will be hold in place through lens fixtures and clamped by nylon washers.

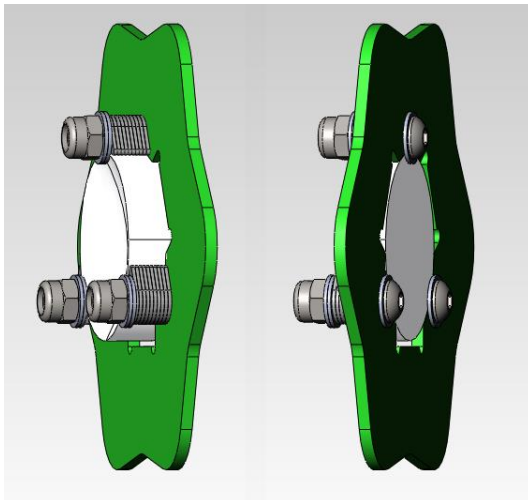

## 5 COMMUNICATION WITH ELA-TR4 FOCUS SHIFTER

### 5.1 MODULATION ELECTRONICS

The focus shifter is powered by a single 12V power supply applied by means of a coaxial connection. Serial data communication (exchanging set point and actual position) is modulated hereon. As a result the SMA connector provides the focus shifter with both data and power supply. Following schematic shows the modulation electronics. Because data traffic and power supply needs to be isolated on both sides of the coaxial connection, the z-axis comprises a similar schematic.

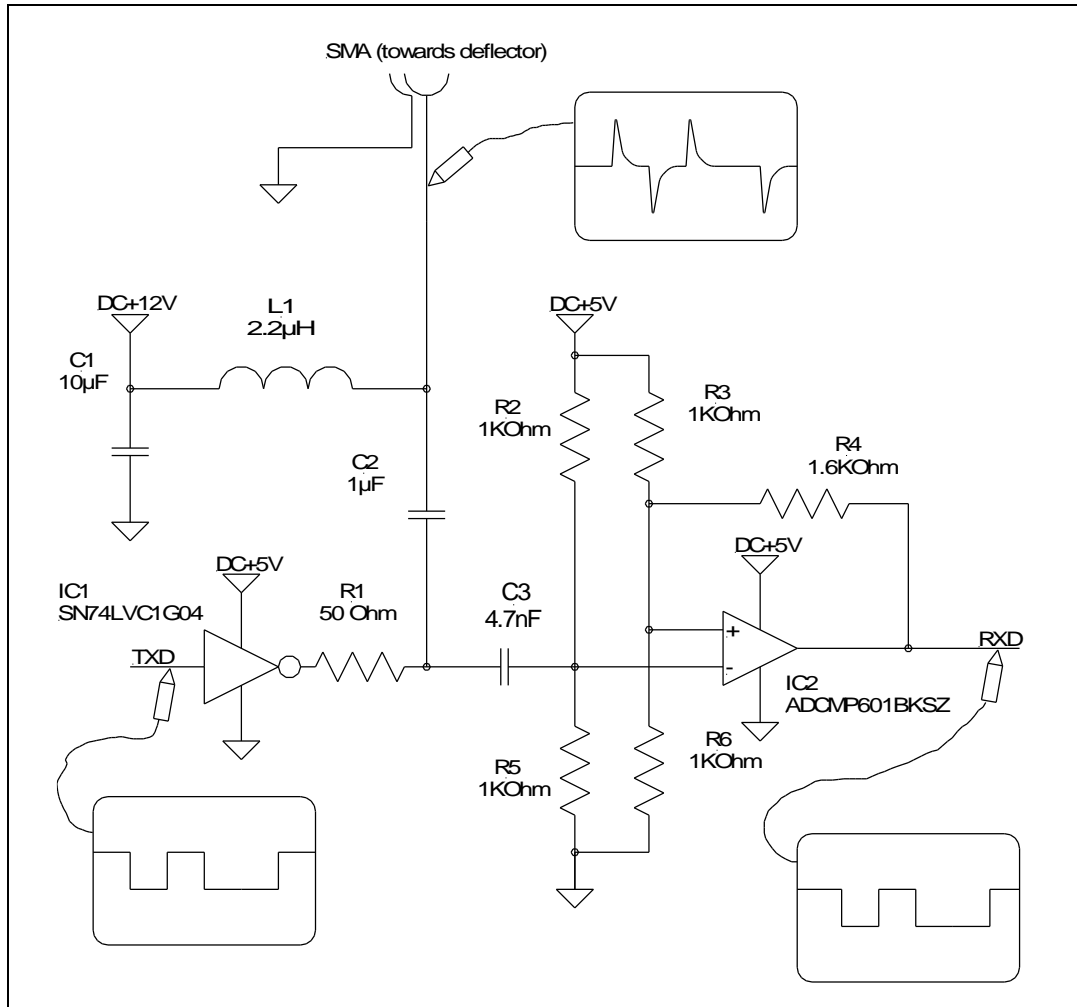

The data towards the actuator (TXD) is high pass filtered while the power supply (DC+12V) is low pass filtered. The high pass filtering is achieved through inductor L1 and resistor R1. Capacitor C2 only serves as a DC level shifter between output amplifier (IC1) and the actuator's power supply. The time constant of the high pass filter equals 44 nsec ( $2.2\mu\text{H}/50\text{Ohm}$ ). The saturation current of inductor L1 should be high enough to handle the actuator's peak currents. The (DC) potential between inner wire and shield of the coaxial connection equals 12V. When the control card sends a data, every TXD bit transition will induce a glitch. Due to inversion by IC1, low going flanks induce positive glitches while high going flanks induce negative glitches. The height of the glitches is about 2.5 V (IC1 powered by 5V). This is the result of the divide by 2 network constituted by the actuator's input impedance and the modulation electronics output impedance (R1). The glitch duration is set by the time constant of the high pass filter.

The returned data is obtained by demodulation using a Schmitt trigger. A positive glitch will reset while a negative glitch will set the Schmitt trigger's output (RXD). The hysteresis is set by the resistor values R3, R4 and R6. When RXD is high, the voltage on the non-inverting input equals 3.1V (IC2 powered by 5V). The voltage on the inverting input is set by the resistors R2 and R5 to 2.5V. A hereon applied positive glitch with amplitude larger than 0.6V will bring the potential above the non-inverting one. The comparator's output becomes low setting the voltage on the non-inverting input to 1.9V. A low going glitch is now needed to set the output back to high.

## 5.2 INSTRUCTION SET

The actuator uses a 20 bit two's complement presentation for both set point and actual position. During operation the set point needs to be controlled by the application. Some applications also need to verify actual focus shifter positions. For ease of use the focus shifter has both a 20 bit and a 16 bit interface to exchange these values. The latter disregards the 4 least significant bits and only accesses the 16 most significant bits.

The instructions and their replies are exchanged with the focus shifter through a half-duplex UART connection. Transmitting a single byte takes 1.1 µsec. Depending on the instruction type the control card sends one or three bytes to the actuator. After reception the actuator will process it and start his reply within 1.5 µsec. To avoid data collision, the time between different instructions must be at least 5 µsec for single byte and 10 µsec for multiple byte instructions.

Instruction overview

Control	Resolution	Size instruction	Size reply	Execution time
20 bit absolute set point	1048576 bits	3 bytes	3 bytes	10 µsec
16 bit relative set point	65536 bits	1 byte	1 byte	5 µsec

UART byte format

Serial data	START, B0, B1, B2, B3, B4, B5, B6, B7, LATCH, STOP
START	Start bit, low
B0..B7	Data byte (B0 least significant bit, B7 most significant bit)
LATCH	Instruction latch (*)
STOP	Stop bit, high

(\*) The instruction set of a focus shifter comprises single and multiple byte instructions. When the LATCH bit is true, the received instruction is interpreted. Single byte instructions must have their LATCH bit set. On multiple byte instructions only the last byte must have the LATCH bit set. All other bytes must be send with LATCH bit cleared. All replies from the actuator are done with LATCH bit cleared.

### 5.2.1 20 bit absolute set point control

With a three byte instruction a 20 bit target position is sent to the focus shifter. Actual position and error bits are replied. When the distance between target and set point is too far, the target position is clipped following a maximum speed principle. The maximum speed whereby the set point is allowed to change, is set at 105 Mbit/sec. When clipping occurred, it is signaled by the error bit ERR\_POS. When this bit is cleared, no clipping was done and the set point is loaded with the target position. When this bit is set, the control card should repeat the instruction in 10 µsec intervals until acknowledged.

The amount of energy consumed by a focus shifter increases with applied target position variations. The actuator has dual stage protection to avoid thermal overloading. When the power consumed by the focus shifter is above maximum load, error bit ERR\_OVLD (overload) becomes high. The control card should respond by reducing the set point speed. When the



power level rises above twice the maximum load the second stage protection switches off amplifier and regulator. The focus shifter stops tracking and sets error bit ERR\_TRACK. After 4 seconds the actuator reboots. During normal operation the error bits should be cleared.

Serial bit sequence (\*):

Instruction Byte 1	START,0,0,0,0,S0,S1,S2,S3,0,STOP
Instruction Byte 2	START,S4,S5,S6,S7,S8,S9,S10,S11,0,STOP
Instruction Byte 3	START,S12,S13,S14,S15,S16,S17,S18,S19,1,STOP
Reply Byte 1	START,ERR_POS,ERR_TRACK,ERR_OVLD,0,A0,A1,A2,A3,0,STOP
Reply Byte 2	START,A4,A5,A6,A7,A8,A9,A10,A11,0,STOP
Reply Byte 3	START,A12,A13,A14,A15,A16,A17,A18,A19,0,STOP

- (\*) S0...S19: new set point (20 bit two's complement, S0 least significant bit, S19 most significant bit)
- A0...A19: actual position (20 bit two's complement, A0 least significant bit, A19 most significant bit)
- ERR\_POS: logic low when new set point is accepted (no speed clipping)
- ERR\_TRACK: logic high when focus shifter has stopped tracking
- ERR\_OVLD: logic high when focus shifter is overloading

### 5.2.2 16 bit absolute set point control

A complete instruction set is available to control and query the 16 most significant bits of both set point and actual position using byte sized instructions. This control mode makes the actuator's full sweep range accessible using 16 bit values. As a result the physical position change pro bit is 16 times larger when compared with 20 bit control. The relative set point control mode is compatible with previous actuator versions.

Controlling the set point is achieved by using µstep move instructions. When the actuator receives such an instruction, its value is added to the set point (16 bit presentation). The valid instruction range is limited from -111 to 111. All values outside this range are interpreted by the actuator as a system instruction, not as a µstep move instruction. Based on a selectable reply mode, a µstep move instruction will be replied with delta actual (mode 1) or echoing (mode 2).

The system instruction set comprises instructions to select reply mode and to query positions. At power up, the focus shifter switches to reply mode 1. In this mode any µstep move instruction will be replied with delta actual. When echoing is desired, the system instruction 126 must be used to change the reply mode to 2. In reply mode 1 it is possible to keep track of the actual position while reply mode 2 allows error control on the communication link.

The maximal speed whereby the set point can be changed using relative control, equals: max speed = max µstep \* max instruction frequency = 111 \* 200 KHz = 22 Mbit/sec The actuators maximal speed is more than three times faster than the speed achievable using 20 bit absolute set point control because every bit is 16 times larger

Single byte instructions

Instruction (*)	Description	Reply
-111...111	µstep move instruction (8 bit two's complement)	Delta actual (when in reply mode 1) Echo µstep (when in reply mode 2)
112	Fetch actual position	Most significant byte actual position
115	Fetch set point position	Most significant byte set point
113	Fetch least significant byte	Least significant byte previous fetch
117	Switch off actuator	0
125	Switch on actuator, set reply mode 1	125
126	Switch on actuator, set reply mode 2	126

(\*) undeclared instruction values are used by tuning and configuration software. Do not use these values

Serial bit sequence (\*)

Instruction Byte 1	START,C0,C1,C2,C3,C4,C5,C6,C7,1,STOP
Reply Byte 1	START,R0,R1,R2,R3,R4,R5,R6,R7,0,STOP

(\*) C0...C7: 8 bit instruction (C0 least significant bit, C7 most significant bit)  
R0...R7: 8 bit reply (R0 least significant bit, R7 most significant bit)

The relative targeting reduces the communication bandwidth. Only variations of the set point are communicated. A new target can't be send directly to the focus shifter but needs to be translated and communicated as a chain of  $\mu$ steps. This chain has to be compiled based on target position, actuator's set point and desired speed. To avoid querying the actuator's set point before every move, the control card should keep a local copy of it. After power up, this copy should be initialized by fetching the actuator's set point (boot cycle reply mode 1 and 2)

Example :

Assume that the actuator is at position 1000 and that ramping towards position 2200 at a speed of 1.2 Mbit/sec is needed

<i>position (local copy of the actuator's set point)</i>	1000 bit
<i>Target (new position)</i>	2200 bit
<i>Speed</i>	1200000 bit/sec
<i>Distance</i>	target-set point = 2200-1000 = 1200 bit
<i>Duration</i>	distance/speed= 1200/1200000 = 1 msec
<i>#<math>\mu</math>steps (number of <math>\mu</math>steps when sending at 5 <math>\mu</math>sec interval)</i>	duration/0.005 = 200
<i><math>\mu</math>step</i>	distance/# $\mu$ steps = 1200/200 = 6

After sending 200 times the value 6, the actuator's set point will be increased with 1200. Sending those values at 5  $\mu$ sec interval will result in a 1 msec. execution time for the ramp.

The actuator has a build in security against thermal overloading. When over steered above twice the thermal rating, it stops tracking. The amplifier and regulator are switched off and the focus shifter stops replying  $\mu$ step move instructions. The control card can respond by sending command 125 (reply mode 1) or 126 (reply mode 2) to restart the focus shifter. Without response within 4 seconds the actuator will reset and a full boot cycle will be needed to restore operation

### 5.2.2.1 Boot cycle reply mode 1 (actual position tracking)

Step 1	Send instruction 125	Setup to reply $\mu$ step move commands with delta actual
Step 2	Send instruction 115	The actuator replies with most significant byte set point
Step 3	Send instruction 113	The actuator replies with least significant byte set point
Step 4	Send instruction 112	The actuator replies with most significant byte actual position
Step 5	Send instruction 113	The actuator replies with least significant byte actual position

After executing step 5, the control card has a 16 bit copy of the actuator's set point and the actual position. Changing the set point is done by sending  $\mu$ step move instructions. The actuator will reply them with delta actual values. By integrating these replies, a live copy of the actuator's actual position can be obtained.

### 5.2.2.2 Boot cycle reply mode 2 (error control on data link)

Step 1	Send instruction 126	Setup to echo received $\mu$ step move commands
Step 2	Send instruction 115	The actuator replies with most significant byte set point
Step 3	Send instruction 113	The actuator replies with least significant byte set point
Step 4	Send instruction 115	The actuator replies with most significant byte set point
Step 5	Send instruction 113	The actuator replies with least significant byte set point

Step 4 and 5 are optional. However they give the advantage of a double read of the set point. The reply of step 2/3 and step 4/5 should be the same. If not you should fetch the set point again. Changing the set point is done by sending  $\mu$ step move instructions. By verifying the replied echo's the integrity of the instruction flow can be verified. If an echo is different from its instruction, the set point should be fetched again (restart at step 2).

### 5.3 POWER UP SEQUENCE

During normal operation the focus shifter only replies on received instructions. All communication needs to be initiated by the control card. The only exception is at power up. 100 msec after power up the actuator sends character 204. This is done to set the Schmitt triggers in the modulation electronics.

When the focus shifter and the control card are powered by the same power supply, the latter should wait for 1 second after power up before sending data to the actuator. During this time, the device boots and initializes all communication electronics. Control card should initialize its TXD output within 100 msec after power up. When the control card's booting process takes longer and said time limit can't be guaranteed different power supplies should be used.

When powered using different power supplies the following power up sequence is advised:

Step 1	power up and boot control card
Step 2	power up actuator, control card polls serial link (RXD) for activity

100 msec after receiving the power up byte (204) from the focus shifter, the control card may send instructions. The control card can use the power up byte to initialize its communication electronics (Schmitt triggers). When the absolute set point control will be used, the control card can start sending the 3 byte sized instructions. When relative set point control will be used, the control card needs to set reply mode and fetch the current position(s) of the actuator prior to sending  $\mu$ step move instructions

## 6 DIMENSIONS

### 6.1 ELA-TR4 WITH STANDARD HOUSING

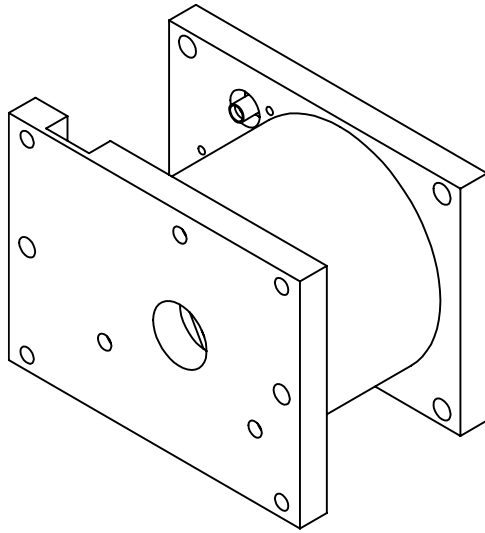

FRONT VIEW

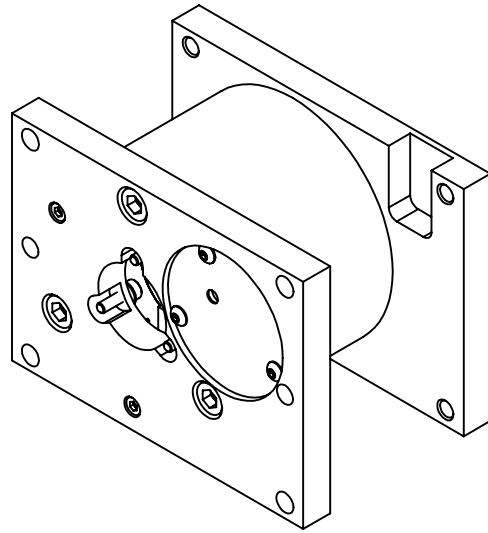

BACK VIEW

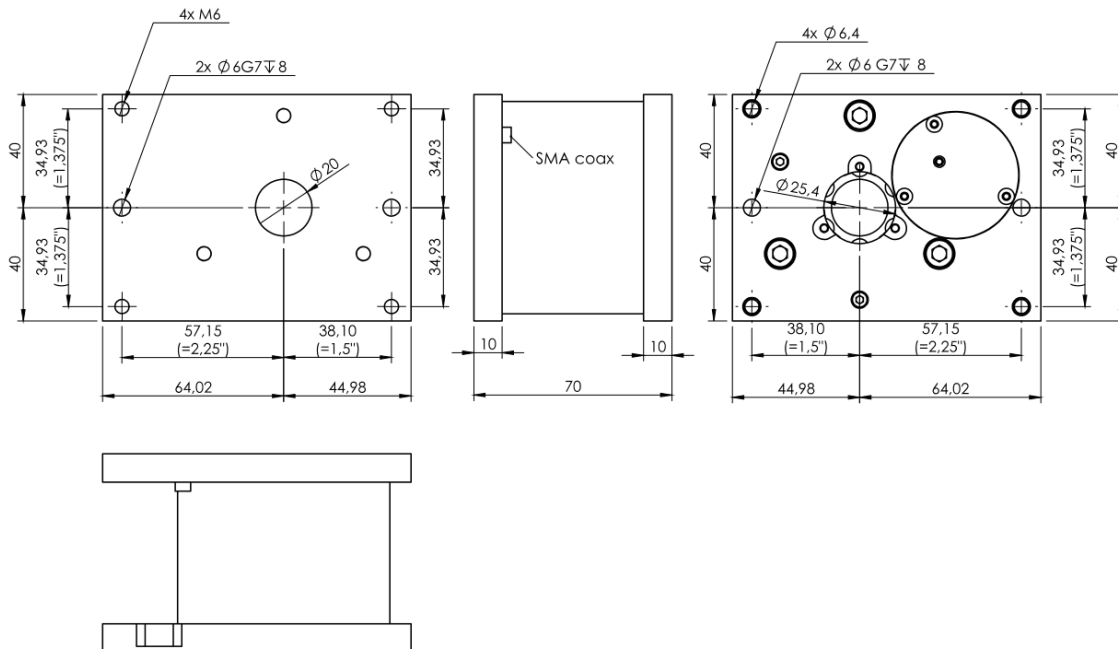

standard dimensions in mm

## 6.2 ELA-TR4 ACTUATOR

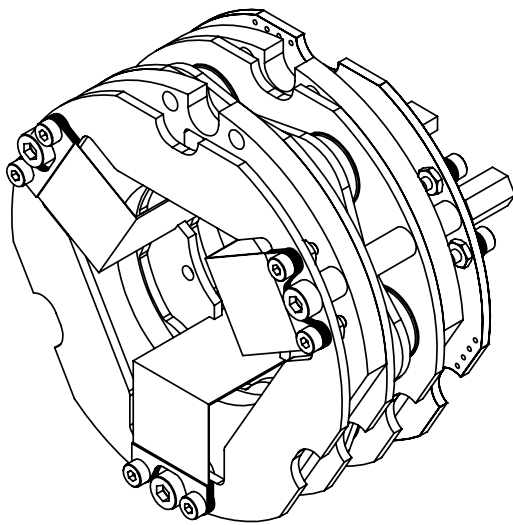

FRONT VIEW

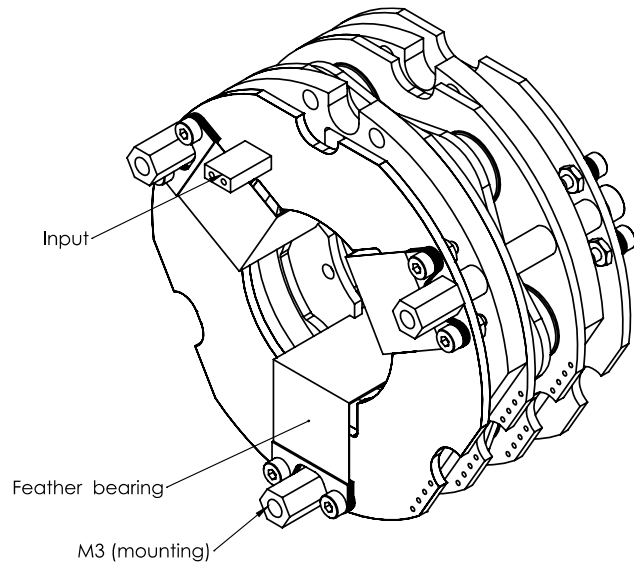

BACK VIEW

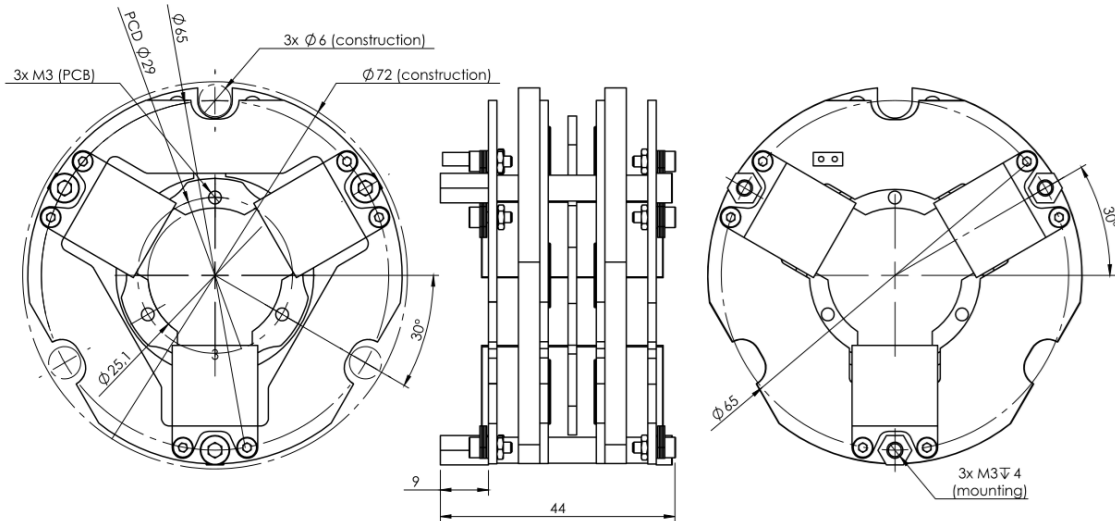

All dimensions in mm